



PowerFLARM Core
Installation Manual
Version 150 (International)

January 19, 2016

Contents

Parts List	4
Working Principle	4
ADS-B alerts.....	5
Installation	6
General Advice on Installation.....	6
Cabling	7
<i>General advice</i>	7
<i>Power supply</i>	7
<i>Circuit breaker</i>	7
<i>Display</i>	8
External antennas	8
<i>FLARM A/B</i>	8
<i>ADS-B</i>	9
<i>GPS</i>	9
Housing	10
Connections.....	11
<i>Overview</i>	11
<i>RJ45: Power and Data Connections</i>	11
<i>D-Sub DE9: Power, Data and Audio Connections</i>	12
<i>FLARM antennas (SMA connector, RED marking)</i>	16
<i>PCAS/ADS-B antenna (SMA connector, BLUE marking)</i>	16
<i>GPS antenna (MCX connector)</i>	16
USB	17
Status LED indications	18
Configuration	20
<i>Operation with Swiss Bat/Aboba v3+/v4 displays</i>	20
Essential Settings Prior to First Flight.....	21
<i>Selection of Aircraft Type</i>	21
<i>Transponder</i>	21
<i>ICAO Address</i>	21
<i>Data Output</i>	22
<i>Range Settings</i>	22

<i>IGC settings</i>	22
<i>IGC task declaration</i>	22
Flight recorder	22
Feature licenses	23
Device identification.....	24
Device update	25
Software, license and/or obstacle database update.....	25
Mandatory firmware update.....	25
Butterfly (BF) software/FlarmNET update.....	25
Technical specifications	27
Notes	28
Product Warranty	28
Replacing 'Classic' FLARM by PowerFLARM	28
Limitations.....	28
FLARM® Radio Communication.....	29
Legal Liability	30
Conformity Declaration	31
Maximum Antenna Gain.....	32
Industry Canada Notice and Marking.....	33
Appendix A: Mechanical Drawings	34
Core.....	34
FLARM and PCAS/ADS-B antenna	35
Appendix B: Antennas	35

Parts List

Your PowerFLARM Core contains the following parts:

- 1 Core (golden metallic box)
- 1 FLARM radio antenna with 1m/3ft cable and SMA connector marked RED
- 1 GPS antenna with 2m/6ft cable
- 1 PCAS/ADS-B antenna with 1m/3ft cable and SMA connector marked BLUE
- 1 power / data cable D-Sub DE9 with 1m/3ft cable and an open-cut end
- 1 USB extension cable (deliveries after January, 2014)

The supplied antennas are suitable for in-cabin installation only. See the Installation section for considerations when using external antennas.

PowerFLARM Core does not have an integrated display, but connects to a wide range of display interfaces, PDA's, on-board flight computers, moving map applications and MFD.

The typical installation connects to a Remote PowerFLARM Display. Suitable cables providing power and data are delivered with the display.

Cable extensions, a choice of antennas and other accessories are available from your PowerFLARM dealer.

Working Principle

Based on GPS and the pressure sensor, PowerFLARM predicts your short-term future flight path and continuously transmits this to nearby aircraft by a digital radio message. FLARM-compatible systems in nearby aircraft receive your radio message and send you a similar message with their data. With such you not only know the whereabouts of aircraft around you, your Core is also able to calculate conflicting flight patterns and alert you of such traffic on a suited display (FLARM functionality).

PowerFLARM also receives data from aircraft with transponders (Mode C and S) or ADS-B OUT (1090ES), and uses these messages for traffic information and alerts (PCAS functionality).

If available, PowerFLARM uses the barometric altitude from a Mode S transponder installed on the same aircraft. If not, PowerFLARM uses barometric altitude derived from the built-in pressure sensor. Barometric altitude is used for determining the relative altitude to PCAS targets.

The effective range depends very much upon the position in which antennas are fitted and facilitates a warning, visual identification, and appropriate action by the pilots in both aircraft.

FLARM-warnings are issued in accordance with the time remaining to a possible collision, not the geometric distance between the aircraft. The first warning is typically issued between 19 and 25 seconds in advance to the calculated possible collision with aircraft or obstacle (time to impact); the second is issued 14 to 18 seconds in advance, and the third 6 to 8 seconds in advance. Warnings are sustained as long as the threat remains as calculated. Depending upon the prediction, the threat may be downgraded or deleted. Warnings are selective, i.e. they are only issued if the calculation detects a high probability of a collision in the immediate future.

PowerFLARM also warns about obstacles on the ground (cables, masts, etc.) if the respective database is installed. Databases are available for purchase on <https://flarm.com/shop/>.

Warnings are disabled if the own aircraft is considered taxiing or stationary on the ground.

ADS-B alerts

ADS-B OUT broadcasts have originally been designed for ground-based surveillance and collision avoidance by Air Traffic Control. The use of ADS-B for *airborne* collision alerts is often limited by factors such as:

- Absence of horizontal and/or vertical speed data
- Absence of GPS altitude data
- Erroneous transmission of position and/or velocity data
- Time lag in position data

Practical experience shows that airborne alerts based on ADS-B can be useful to warn about powered traffic in cruise or relatively flat turns such as standard procedure turns.

However, ADS-B does not provide sufficiently precise data to warn about glider traffic with its frequent altitude changes and steep turns.

To ensure best alert quality, PowerFLARM therefore does not use ADS-B data to compute alerts for glider targets. Instead, it will exclusively rely on the target's much more precise FLARM data.

This requires that all gliders which are equipped with FLARM *and* ADS-B transponders to correctly configure their ADS-B out *emitter category* to **glider**. Please refer to your transponder's manual in order to make that configuration. To ensure reliable alerts, it is important that gliders equipped with ADS-B transponders also carry a compatible FLARM or PowerFLARM device and that both devices are configured to the same ICAO address.

Please contact your local dealer if you're experiencing difficulties with the above recommendations your flying area.

Installation

General Advice on Installation

Installation and operation is on a non-interference and non-hazard basis, and may not endanger the safe operation of certified equipment that is either necessary or required by regulation for safe flight. Installation must comply with official requirements. In EASA countries, an MCA (Minor Change Approval) or Standard Change installation with appurtenant documents is required. This can be acquired from:

<https://flarm.com/shop/easa-minor-change-approval-mca/>.

Core must not obstruct the pilot in his operation of the aircraft (including emergencies); in particular, at all times it must not obstruct his view of the airspace, even in the event of serious vibration or acceleration. Core is not suitable for use in conjunction with night vision equipment, for night flying, or in pressurized cabins.

Only one single FLARM-compatible system may be installed per aircraft.

Core should be located at least 1ft away from the magnetic compass.

After installation, an inspection must be made to ensure that the Core does not interfere with any mechanical, electrical, electronic (radio) or magnetic (e.g. compass) system, and this fact must be recorded in the aircraft documents. In addition, the aircraft documents must bear a record of the PowerFLARM Core serial number and Software Version Number. The Means of Compliance must be recorded in the aircraft documentation and an AFM Supplement is to be carried on board the aircraft. An EASA approved AFM Supplement is available as part of the MCA (Minor Change Approval) linked above.

Please see also the Quick Checklist for FLARM installation on <http://flarm.com/support/manuals-documents/>.

Cabling

General advice

- Before connecting your cables for the first time, check all connectors with a continuity tester. Pay special attention to the Power Supply pins.
- For updates and configuration, the USB connector must be accessible, where required with an installed extension cable.
- Cables must not be cracked or installed under tension. Adequate space must be left for the cable connectors.

Power supply

- Supply voltage: 8 to 35VDC.
- Typical current drain 165 mA @ 12V, less for higher voltages, more if external components are supplied by PowerFLARM.
- Connect power either through the D-Sub (pin 7) or the RJ45 connector (pin 1 and 2); do not provide power to both!

Circuit breaker

- Connect PowerFLARM Core via a dedicated pilot-operated 1-3 A CB or combined CB/Switch.

- The PowerFLARM CB must be separate from other CBs of essential avionics.
- In flight the pilot must be able to isolate PowerFLARM Core from the aircraft's electrical power system without interrupting the power supply to other essential avionics.

Display

- Use high quality shielded cable for the RX and TX connections.
- Up to 5m cable length are acceptable.
- In case the display requires 3VDC operating voltage, the respective connection on the RJ45 or D-Sub connector may be used. Otherwise, the display should be supplied directly from the aircraft's bus and protected by its own CB as per the display's installation manual.

External antennas

The antennas provided with PowerFLARM Core are suitable for in-cabin use only. External antennas for FLARM and ADS-B are however recommended for most aircraft. If external antennas are installed, please follow the considerations below.

- Ensure high quality in custom-made cable/connector assemblies.
- Minimize cable lengths to ensure maximum signal strength.
- Antennas should be spaced at least 30cm apart, including other antennas like COM/NAV, XPDR etc.
- See also the 'Connections' section for antenna and placement considerations.

FLARM A/B

- Use low-loss 50Ω coaxial cable such as Aircell 7, RF-240, LMR-195, RG-58 or RG-174.
- Total attenuation of the cable at 900MHz should not exceed 3dB. This translates into a maximum cable length of ca. 15m for Aircell 7 or 3m for RG-174.

- If higher cable lengths are required, even lower loss cables such as LMR-400 should be considered.
- Suitable antennas: FLARM AV-75 (part. No. ANTCEFLA and ANTCEFLAB); available from your FLARM dealer.
- The primary antenna (FLARM A) should have good view into the direction of flight. FLARM B (if used) should be placed to complement the field of view of FLARM A.

ADS-B

- Suitable antennas: RAMI AV-74 Transponder/DME antenna or similar; available from your FLARM dealer.

GPS

- Use low-loss 50 Ω coaxial cable. Attenuation values at 1.57GHz are relevant.
- The required MCX connector can be directly crimped to RG-316 and Enviroflex (ca. 1.4dB/m). If thicker cables are required, an adapter must be used.
- Use a low-profile aviation GPS antenna with builtin preamplifier, e.g. Sensor Systems S67-1575-39 or S67-1575-49; available from your FLARM dealer.
- Preamplifier gain minus cable attenuation must exceed 17dB.
- The antenna must accept PowerFLARM's 4.75V supply and must not draw more than 200mA. DC resistance of the cable must be taken into account.
- The antenna should be mounted horizontally with a good sky view.
- Operation with an existing GPS antenna and an RF splitter may be possible provided the antenna has a high gain preamplifier and cable losses are not too high. A splitter with a DC block on one path must be used. Please contact your dealer or FLARM if you plan using a splitter.

Housing

The metallic housing is not waterproof and users should avoid the ingress of solid particles and liquids. Should the unit get moist, it must be completely dried prior to further use. If the unit becomes wet, it may be permanently damaged and rendered unusable; no warranty claim will be accepted for any unit damaged by moisture or liquids. Should the unit be suddenly cooled this may result in the formation of condensation.

Connections

Overview

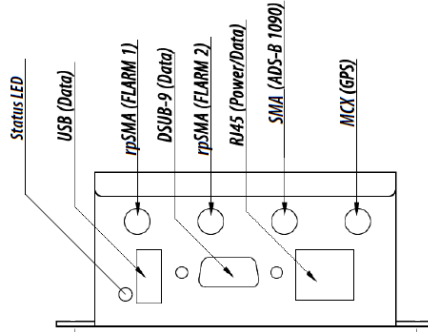

Core has the following connectors:

- USB 2.0: Flight log readout, device update and configuration
- FLARM antennas A and B: When using a single antenna, connect to FLARM A. Antenna connector has a RED marking. Use of FLARM B requires a feature license.
- ADS-B/PCAS: For receiving transponder signals. Antenna connector has a BLUE marking.
- GPS antenna: Must be connected for proper operation in flight.
- Data Ports #1 (RJ45) and #2 (D-Sub DE9): For connecting up to two independent displays/PDAs/flight computer. Also used for power supply of Core. RX/TX on ports #1 and #2 can be configured and used independently.

RJ45: Power and Data Connections

The 8-pin RJ45-socket is in accordance with IGC GNSS FR specifications, except for pin 3. Pin numbering follows IGC's convention (<http://www.fai.org/gnss-recording-devices/igc-approved-flight-recorders>):

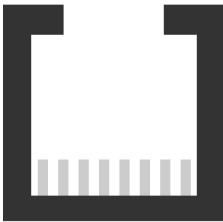

Pin 1 Pin 8

- 1: +12 to +28VDC power supply
- 2: +12 to +28VDC power supply
- 3: Core supplies +3VDC for display
- 4: GND
- 5: TX, Core sends (RS232)
- 6: RX, Core receives (RS232)
- 7: GND
- 8: GND

Pin 5 transmits NMEA-0183 Version 2.0 data at a configured data rate (default is 19.2kbaud). Further FLARM-specific data is available for periphery devices (e.g. remote display).

Do not connect more than one external application to the port.

Maximum current on pin 3: 200mA @ 3VDC.

D-Sub DE9: Power, Data and Audio Connections

The 9 pin DE9 connector is shown below. On the left side the female socket on the PowerFLARM is shown. On the right side the male plug (on the cable) is shown.

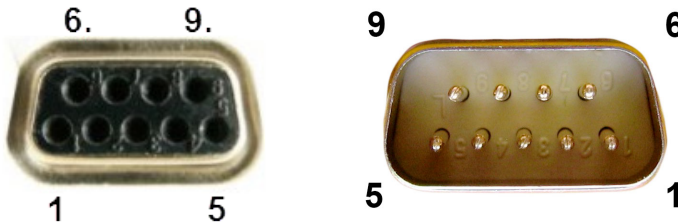

- 1: Audio OUT (referenced to GND; H/W versions \geq 1.1 only)
- 2: TX, Core sends (RS232)
- 3: RX, Core receives (RS232)
- 4: Do not connect
- 5: GND
- 6: Do not connect
- 7: +12 to +28VDC power supply
- 8: Core supplies +5VDC for PDA
- 9: Core supplies +3VDC for display

Pin 2 transmits NMEA-0183 Version 2.0 data at a configured data rate (default is 19.2kbaud). Further FLARM-specific data is available for periphery devices (e.g. remote displays).

Do not connect more than one external application to the RS232 port.

Maximum current on pin 9: 200mA @ 3VDC; independent of pin 3 of the RJ45 connector.

Maximum current on pin 8: 700mA @ 5VDC; shared with the USB port.

Avoid using the 5VDC supply from the USB port and the D-Sub port at the same time.

WARNING!

The below color assignments are only valid for specific D-Sub cables which have been shipped with devices from 2016.

D-Sub cables shipped with PowerFLARM Core devices from 2016 are color coded according to the following table. These D-Sub cables are marked with “Art.-Nr 1420531”. **DO NOT use the color coding if the cable is not marked accordingly.**

Grey	Pin 1: Audio OUT
Yellow	Pin 2: TX, Core sends (RS232)
Green	Pin 3: RX, Core receives (RS232)
Brown	Pin 4: Do not connect
White	Pin 5: GND
Red	Pin 7: +12 to +28VDC power supply
Pink	Pin 8: Core supplies +5VDC for PDA
Blue	Pin 9: Core supplies +3VDC for display

Note: There is no wire for Pin 6!

Pin 7 of the D-Sub connector and Pins 1 and 2 of the RJ45 connector are internally connected. So are the GND pins 5 (D-Sub) and 4, 7, 8 (RJ45).

Audio OUT

Audio OUT (pin 1) is available for hardware version 1.1 and later (FLAPFC11...), provided the corresponding feature license is installed. PowerFLARM emits 1kHz beeps on Audio OUT whenever dangerous traffic is detected. A test beep is emitted after power up.

Dedicated PowerFLARM displays have their own sound generator (buzzer). Audio OUT is only necessary when the buzzer of the connected PowerFLARM display(s) is not loud enough to be heard in a high-noise environment.

Electrical characteristics:

- AC signal, 1.7V peak-to-peak @ 1 kOhm
- Referenced to GND (pin 5), no DC bias
- Output impedance: 47 Ohm
- Output current (max.): 35mA

Connect Audio OUT to audio panels or other amplifiers with input impedance between 200 Ohm and 10 kOhm. The audio panel or amplifier should allow volume adjustment.

Do not connect a passive headset or speaker directly to Audio OUT. If you are unsure about how to connect Audio OUT, contact your dealer.

FLARM and PCAS/ADS-B antenna connectors (SMA)



US/Australia devices (part No. FLAPFCnnA and FLAPFDnnA): FLARM A and B are reverse polarity female SMA connectors with a pin as center conductor. ADS-B is a standard female SMA connector with a female center sleeve.



European devices (part No. FLAPFCnnE and FLAPFDnnE): FLARM A and B ports are standard female SMA connectors with a female centre sleeve. ADS-B is a reverse polarity female SMA connector with a pin as a centre conductor.

Never swap the FLARM and PCAS/ADS-B antennas. Doing so may cause permanent mechanical damage to the device and will void warranty.

The difference between US/Australia and European devices is due to regulatory requirements.

Both FLARM and the ADS-B antennas must be mounted vertically (i.e., one tip facing up, the other one down).

FLARM antennas (SMA connector, RED marking)

Core has two separate FLARM radio transceivers FLARM A and FLARM B. **FLARM A is used to receive and transmit and must always be connected to an antenna.** FLARM B is only used to receive; an optional antenna may be used for better reception performance.

Usage of FLARM B requires purchase of the respective feature license.

Ensure the antennas are properly and fully screwed into Core. **Never swap the FLARM and the PCAS/ADS-B antennas.** Use only little force when inserting and tightening (1 Nm max). Ensure the antennas are not in contact with any other object through which there might be a regular electrostatic discharge, e.g. the canopy. In case you use two FLARM antennas, ensure they are separated by at least 5ft.

Ideal locations for the FLARM antenna are:

- On the coaming of the instrument panel, in front of the compass (4 inch, 10cm minimal distance to compass)
- In the tail fin of the aircraft, if not metallic or carbon. Use only extension cables available from FLARM dealers.
- Behind the pilot's head in the glider fuselage (not in gliders with carbon fuselage)

The FLARM antenna must be vertically (i.e., one tip facing up, the other one down).

PCAS/ADS-B antenna (SMA connector, BLUE marking)

Core has one PCAS/ADS-B receiver operating on 1090MHz. Ensure you properly and fully screw the antenna stub into Core. **Never swap the FLARM and the PCAS/ADS-B antennas.** Use only little force when inserting and tightening (1 Nm max).

This antenna should be placed at least 1ft away from the FLARM antenna(s). The FLARM antennas have priority over this antenna for best placement.

GPS antenna (MCX connector)

PowerFLARM Core contains a 50 channel GPS receiver, connecting to an external antenna. Ensure you properly and fully plug the GPS

antenna cable connector into Core. PowerFLARM will not work without good GPS reception.

The GPS antenna should be located in a horizontal position such that it has an unhindered sky-view, including when the aircraft is in a turn. There should be no electrically conducting surfaces (e.g. metal, carbon fibre) over or immediately alongside the antenna. Ideally, the antenna will sit atop the instrument panel coaming. Conducting surfaces under the antenna may have a positive effect upon antenna function.

If more than one GPS antenna is present in the aircraft, it is recommended that they are at least 1ft apart; the same holds for separation from all other Core antennas.

USB

Core has a built-in USB A 2.0 connector for a memory stick. The stick is used for device updates and readout of device information and flight records. See the section 'Device update', 'Flight recorder' and 'Feature licences' for details. Maximum size is limited by FAT system (32GB).

The USB stick must not be connected during flight except for special purposes as advised by FLARM Technology or its agents.

USB stick transactions take place:

- Whenever PowerFLARM is switched ON with a USB stick connected.
- When triggered by a display or flight computer (currently implemented: Readout of flight records).

Transactions after switching PowerFLARM ON are executed in the following sequence:

- Apply device configuration (FLARMCFG.TXT)
- Write device information (FLARMDEV.CSV)
- Updates: Firmware, obstacle database, licences. (PowerFLARM restarts if any update is done (Status LED OFF for three seconds); this is to allow expedited updates of multiple devices.)

- Butterfly display firmware update
- Flight record readout

USB sticks should:

- be formatted with FAT (FAT16 or FAT32) file system (NTFS or exFAT will not work)
- have capacity \leq 32GB
- Be of USB 2.0 type (not USB 3.0; USB 3.0 connectors are typically blue on the inside).

Suggestions for USB stick usage:

- Use a dedicated USB stick for your PowerFLARM device(s) (Exception: Updates of multiple devices to the same software and/or obstacle DB).
- Leave flight logs (IGC files) on your USB stick during the flying season. This will reduce the time needed for readout, because files already on the stick are skipped.
- Sort IGC files by date on your PC. The last file in the list then corresponds to the most recent flight.
- If multiple firmware update files are on the USB stick, PowerFLARM will chose the most recent one.
- Do not keep multiple obstacle database updates on your USB stick.
- PowerFLARM will skip firmware, license and obstacle database updates which are already installed.

Status LED indications

The Status LED can show three different colors: GREEN, ORANGE and RED.

Please note that ORANGE may appear similar to RED. The color during the first few seconds after startup is ORANGE.

The meaning of the Status LED indications is as follows:

- GREEN: Core operates normally
- ORANGE during start-up sequence: May take up to 20s

- Permanent RED: Error condition, no operation possible (e.g. no GPS reception, low voltage)
- Permanent ORANGE: Warning condition, operation possible (e.g., obstacle database out of date)
- RED/GREEN flashing: on-going data upload/download with USB memory stick
- OFF: no power

Indications while reading FLARMCFG.TXT files:

- One long GREEN flash: USB stick detected
- One short GREEN flash for each command executed successfully
- One short RED flash for each command causing an error (verify FLARMCFG.TXT in that case)

Configuration

Prior to first use, PowerFLARM Core must be configured correctly.

Failure to configure or a false configuration may lead to failure to alert, operate or cause nuisance alarms!

To configure your Core:

- Use the online Configurator tool to generate a file FLARMCFG.TXT: <http://flarm.com/support/tools-software/>
- Copy this file to the top directory of your USB stick.
To update many devices using one USB stick, name each configuration file as follows: CF<Product Code><5 last digits of Serial Number>.txt, where Product Code is the 6th letter from Part Number (C, D, P, or Q), which you can find on device sticker. Example: Part Number FLAPFD11E, Serial Number 002217, Configuration file name CFD02217.txt
- Connect the stick to the Core and power on the system.
- Wait until the system has completed the startup sequence.

The Status LED will issue a long GREEN flash to acknowledge the presence of the FLARMCFG.TXT file and a short GREEN flash for each configuration line executed. RED flashes indicate an error, please verify your FLARMCFG.TXT file in that case.

Please use FAT formatted USB 2.0 sticks; see the USB section for details.

The configuration is stored permanently in Core internal memory. During normal operation, the USB stick should be removed from the Core.

All configurations can also be made via the RS232 interfaces of the Core. Please refer to your display or flight computer's documentation for details.

Operation with Swiss Bat/Aboba v3+/v4 displays

- Select 'Traffic Data Only' for the 'Data Sentences' option.
- Select 'Default' for the 'Data sentences protocol' option.

- Select 'Send PCAS targets to LED displays' under 'Data Output' (only relevant for non-Pure devices).
- Ensure that the Display and PowerFLARM Core use the same Baud rate.

Essential Settings Prior to First Flight

There are a number of device settings that *must* be configured prior to the use of the device. These are aircraft-specific settings, that can be found in the configuration file. The values chosen depend upon the aircraft and *must* be altered before the device is used in another aircraft.



These settings are mandatory for correct operation of the device.

Selection of Aircraft Type

This setting is required to specify the type of aircraft in which your device will be used.

Transponder

Select whether your aircraft has an operating transponder (any Mode) installed and switched ON, or not.

ICAO Address

Enter the hexadecimal ICAO address of your aircraft. This address is also known as Mode S Code. It is worldwide unique for each aircraft and issued by your Civil Aviation Authority (regardless of whether you have a Mode S transponder installed or not). In case you have a Mode S transponder installed, this is also the address transmitted by the transponder.

The ICAO address can be found in the aircraft documents or online:

- <http://www.faa.gov/> (US; see 'N-Number Inquiry', use **Mode S Code (base 16/hex)**; addresses start with A0..A9 or AA..AF)
- <http://www.bazl.admin.ch/experten/luftfahrzeuge/luftfahrzeugregister/> (Switzerland; use **Aircraft Address hex**; addresses start with 4B)



Incorrect settings will result in false warnings or a failure of the warning function. This also applies to your Mode S/ADS-B transponder (if installed). Both PowerFLARM and the transponder must be set to the correct address.

Register your hex ICAO address for free at www.flarmnet.org

Data Output

This affects the communication with the display. Recent FLARM displays are able to autoconfigure PowerFLARM according to their needs. In this case no changes from the defaults are required. Consult the display documentation for details.

Select Garmin TIS for TIS compatible devices (requires the respective feature licence).

Warning: Due to protocol limitations, traffic information using Garmin TIS may be too coarse for quick visual identification. A FLARM compatible device should be used as the primary FLARM display.

Range Settings

We recommend ranges useful for collision avoidance, e.g. 600m for vertical and 5km for horizontal ranges.

IGC settings

Here you can set pilot name, callsign etc. for the IGC flight recorder.

IGC task declaration

Please use your gliding computer or standard gliding software packages for declaring tasks.

Flight recorder

In addition to providing traffic and obstacle warnings, your Core operates as an IGC file compatible flight recorder.

Options for diamond-level IGC approval and for Engine Noise Level recording (ENL) are available, see the section about Feature licences.

Core has internal memory for around 100 hours of flight recording at a 4s interval. Flight recording automatically starts when the aircraft starts moving and ends when the Core is switched OFF or after more than 10 minutes of standstill. When the memory is full, the oldest flights are overwritten first.

To read out the flights to the USB stick:

- Switch Core OFF after flight (allow at least 2 minutes after landing to avoid losing data).
- Connect USB stick to Core.
- Switch Core ON.
- Observe Status LED (flashing RED/GREEN) or progress indication on display to verify flights are being copied.
- Wait until system has started up normally after copying flights.
- Disconnect USB stick.

Some displays or flight computers allow reading out flights without switching the Core OFF after the flight. Please refer to your system's documentation for details.

Please use FAT formatted USB 2.0 sticks. See the USB section for details and recommendations about USB stick usage.

Feature licenses

Starting with Firmware version 3.00, some features of the Core require a license. These features are:

- AUD: Audio output connection (available from Hardware version 1.1)
- ENL: Engine noise level sensor
- IGC: IGC approval
- TIS: Garmin TIS interface
- RFB: Second FLARM antenna connector

Devices sold prior to Software version 3.00 have pre-installed 'grandfather' licenses for the features they were sold with (e.g., devices sold in the US prior to 2013 have IGC, TIS and RFB).

Licenses can be obtained directly from FLARM or, in some cases, from your dealer.

Each license requires a device-specific license key. Keys are stored in files named xxx.LIC and are installed via the USB port, see 'Device update' below. Once a license is installed on the Core, it will remain there permanently. Nevertheless, please keep a backup copy of your license keys.

Device identification

In order to obtain licenses, you'll need:

- The device type (PowerFLARM Portable or Core)
- The serial number

The serial number has the form FLAPFC11E-001234.

PowerFLARM also writes essential device information to a file FLARMDEV.CSV whenever a USB stick is connected on startup. If the USB stick is shared between multiple devices, each device appends a line with its own information to the end of the file.

The FLARMDEV.CSV file contains the following information:

- Device type, serial number and region
- Device capabilities
- Installed feature licenses
- ICAO ID and callsign (if defined), aircraft and transponder type
- Some internal system information

PowerFLARM writes the same information to IGC files.

Some displays and flight computers show the device identification on startup or on request. Please refer to your system's documentation for details.

Device update

Installation and update of PowerFLARM software, licenses and the obstacle database is via USB. The software of some FLARM displays (currently supported: Butterfly) can also be updated via the Core. Please use FAT formatted USB 2.0 sticks; see the USB section for details.

Software, license and/or obstacle database update

- Copy relevant file(s) (xxx.FW, yyy.LIC, zzz.OB2) to USB stick.
- Connect stick to Core.
- Switch on system.
- Verify status LED flashes RED/GREEN.
- Wait until LED turns solid GREEN (or RED in case of no GPS reception).

Some displays or flight computers will show a progress indication during the update. Please refer to your system's documentation for details.

Mandatory firmware update

In order to allow global changes to the FLARM system, every FLARM/PowerFLARM device needs to be updated with the latest firmware version at least once per year (rolling 365 days). This has to be part of the Aircraft Maintenance Program (AMP). The entry in the AMP is to be made during installation. A new update shall be required within 365 days of the previous update.

Each firmware also has a fixed expiry date, to avoid that devices which have not been updated are transmitting obsolete data. All FLARM/PowerFLARM devices will start warning about imminent expiry 60 days prior to the expiry date.

Butterfly (BF) software/FlarmNET update

- Copy Butterfly software (.BFW) and/or flarmnet (.BFN) to USB stick.
- Connect stick to Core.

- Switch system ON with BF display knob pressed.
- Verify BF display goes into UPDATE MODE with 'WAITING', then 'LOADING'.
- Wait until BF display restarts (can take up to two minutes).

Multiple displays on separate Data Ports need to be updated sequentially: Press the BF display knob only on one display, then repeat the procedure for the other display.

Note: This procedure is only supported for displays directly connected to PowerFLARM, i.e. not via a 3rd party repeater or Y adapter. For Y adapters and repeaters, please consult the display and respective 3rd party documentation.

Technical specifications

Technical specifications are subject to change without notice. Usage of some features requires purchase of a licence.

	PCAS/ADS-B	Pure
Dimensions	120 x 80 x 41 mm	
Weight	285 g	250 g
Power supply	8 to 35 VDC	
Current consumption (no external consumers)	165 mA @ 12 VDC	95 mA @ 12 VDC
Supply for external devices	1 x 250 mA @ 3 VDC (D-Sub, RJ45) 1 x 700 mA @ 5 VDC (D-Sub, USB) 1 x 200mA @ 4.75 V (supply for GPS antenna LNA, MCX)	
Data Ports	D-Sub DE9 and RJ45; RS232 connection, NMEA @ 4.8-57.6kBaud, TIS @ 9.6kBaud	
Audio OUT (H/W versions >= 1.1 (2013) only)	AC, 1.7 V peak-to-peak @ 1 k Ω	
GPS	External 50 Ω active (LNA) antenna; MCX connector. Accuracy \leq 5 m (typ.)	
Radio (FLARM)	2 channels, 868 MHz SRD band (Europe)/902 to 928 MHz ISM band (North America, Australia)	
Radio (PCAS/ADS-B)	1090 MHz	None
USB	Connector for USB 2.0 sticks; FAT formatted, 32 GB max.	
Operating temperature	-40 to 85 $^{\circ}$ C	
Detection range	5-8km typ., depending on antenna and installation	

Notes

Product Warranty

The warranty is immediately void should the unit be opened, mis-used, installed faulty, and any breach of copyright.

Replacing ‘Classic’ FLARM by PowerFLARM

The following considerations apply when replacing Classic FLARM by PowerFLARM:

- PowerFLARM typically has a higher FLARM radio range and can use a second antenna.
- PowerFLARM does not have a built-in display. Displays compatible with Classic FLARM are also compatible with PowerFLARM. However, not all displays support undirected (PCAS) targets. Please ask your display manufacturer or dealer for details.
- PowerFLARM is not supported by the PC software FLARM Tool (for updating and configuring Classic FLARM). Please use the online configurator instead (see ‘Configuration’).
- Firmware update, IGC file download and obstacle data upload is via USB only, not via the Data Ports. Functions in 3rd party devices or software for flight download/obstacle data upload to Classic FLARM will not work with PowerFLARM. We strongly recommend installing a USB extension cable with an easily accessible connector unless PowerFLARM’s own USB connector is accessible. USB data transfer is faster than over the Data Ports.

Limitations

Operation of PowerFLARM is restricted to the region it was sold for.

PowerFLARM has been designed as a non-essential situation awareness only unit, whose task is solely to support the pilot; it is not always in a position to provide a reliable warning. In particular, PowerFLARM does not provide any resolution advisory (recommended evasive action). Under no circumstances does PowerFLARM facilitate a change in flight tactics or pilot conduct. Even though you have installed PowerFLARM, you remain responsible

and liable for the safety of all passengers and other aircraft. Operation of PowerFLARM is solely a matter at the discretion of the pilot. The unit may only be operated by persons who have carefully studied all user instructions.

A display attached to PowerFLARM can only alert of the presence of other moving aircraft if the other aircraft is equipped either with a FLARM-compatible system, an ADS-B OUT (1090ES) on 1090MHz or an interrogated transponder Mode C or S. PowerFLARM does neither interrogate transponders nor operate as a transponder, and is thus neither detected by TCAS nor air traffic control.

PowerFLARM has not undergone the conventional aeronautical certification process. PowerFLARM software development was conducted in accordance with the usual standards and procedures required for industrial electronics products. The use of public access unlicensed radio bandwidths in the air is subject to a number of limitations, with some national differences. The pilot is solely responsible that PowerFLARM is operated in accordance with the valid local regulations.

The use of PowerFLARM is strictly limited to flights in VMC (Visual Meteorological Conditions). PowerFLARM may not be used for navigation.

FLARM® Radio Communication

The PowerFLARM radio communications are made using a public frequency band not requiring a user licence. This means that the band is also used by a number of other applications. PowerFLARM has no exclusive rights to use the frequency band, so there is no guarantee that PowerFLARM reception will be free from interference by other users.

Essentially, the PowerFLARM communications protocol places little limit on the number of units that may be contacted within the working range. However, an increasing number of units within range leads to a reduction in the probability (graceful degradation) that a single radio message can be received. But the probability that the next signal from the same transmitter will not be received is generally small. A large number of signals from other aircraft does not reduce the working range.

Communications between FLARM-compatible units such as Power-FLARM employ a proprietary copyright protected protocol. The design is patent protected. Any unlicensed use, copying, distribution, conversion, replication, de-compiling, reverse engineering, or further transmission of knowledge so acquired relating to the system components or software, in whole or in part, is forbidden and will result in legal enforcement action. FLARM® is an internationally registered trademark and may not be used by third parties without a license. Technical data may be changed at any time and without prior warning. Some named functions are not provided in all versions, but may be provided at extra cost.

Legal Liability

FLARM Technology GmbH, also its agents, designers, component suppliers, manufacturers and data suppliers accept no legal liability or responsibility for damage or legal claims.

Conformity Declaration

FLARM Technology GmbH, Lindenstrasse 4, CH-6340 Baar, Switzerland, declares that the product *PowerFLARM Collision Warning Device* in Hardware Version FLAPFC1*E and typical configuration, meets the requirements of the CE mark.



The communications conformity meets the requirements of EN 300 220 (power class 9), EMC- Conformity EN 301 489 (class 3 SRD-Device, equipment type I). The device is in accord with the requirements of the European R&TTE Directive.

This device complies with Part 15 of the FCC. Operation is subject to the following two conditions: (1) this device may not cause harmful interference, and (2) this device must accept any interference received, including interference that may cause undesired operation.

FCC ID:
ZKUGC625162

Within the USA, the device may only be used in transportation vehicles such as aircraft or motor vehicles.

This Class A digital apparatus complies with Canadian ICES-003.

IC ID Number:
10154A-FLAPFC10

Cet appareil numérique de la classe A est conforme à la norme NMB-003 du Canada.

Maximum Antenna Gain

Currently, the maximum antenna gain for external antennas is limited to 2.0dBi for operation in the 902MHz to 928MHz bands. The antenna gains must not exceed maximum EIRP limits set by the FCC / Industry Canada.

Actuellement, le gain d'antenne maximal d'antennes externes est limité à 2.0dBi pour un fonctionnement en 902MHz à 928MHz par points à bandes. L'antenne gain doit pas être supérieure à maximum EIRP limites fixées par la FCC/Industrie Canada.

Industry Canada Notice and Marking

Under Industry Canada regulations, this radio transmitter may only operate using an antenna of a type and maximum (or lesser) gain approved for the transmitter by Industry Canada. To reduce potential radio interference to other users, the antenna type and its gain should be so chosen that the equivalent isotropically radiated power (e.i.r.p.) is not more than that necessary for successful communication.

Conformément à la réglementation d'Industrie Canada, le présent émetteur radio peut fonctionner avec une antenne d'un type et d'un gain maximal (ou inférieur) approuvé pour l'émetteur par Industrie Canada. Dans le but de réduire les risques de brouillage radioélectrique à l'intention des autres utilisateurs, il faut choisir le type d'antenne et son gain de sorte que la puissance isotrope rayonnée équivalente (p.i.r.e.) ne dépasse pas l'intensité nécessaire à l'établissement d'une communication satisfaisante.

This device complies with Industry Canada licence-exempt RSS standard(s). Operation is subject to the following two conditions: (1) this device may not cause interference, and (2) this device must accept any interference, including interference that may cause undesired operation of the device.

Le présent appareil est conforme aux CNR d'Industrie Canada applicables aux appareils radio exempts de licence. L'exploitation est autorisée aux deux conditions suivantes : (1) l'appareil ne doit pas produire de brouillage, et (2) l'utilisateur de l'appareil doit accepter tout brouillage radioélectrique subi, même si le brouillage est susceptible d'en compromettre le fonctionnement.

Appendix A: Mechanical Drawings

Core

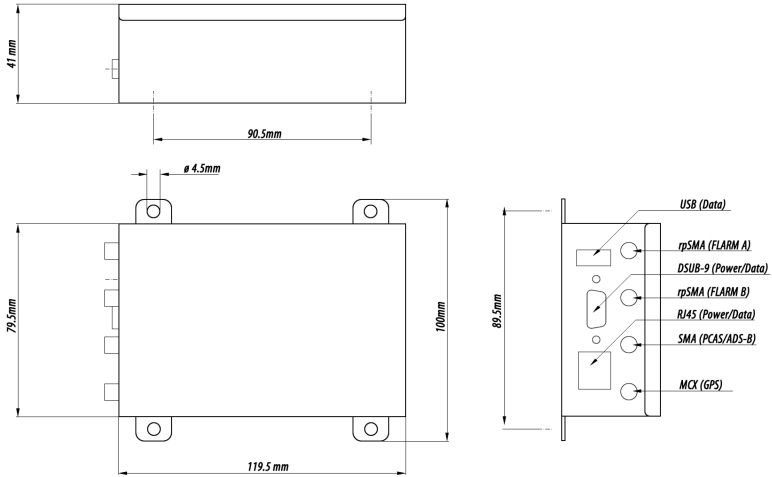

FLARM and PCAS/ADS-B antenna

Please see below for an indicative drawing of the FLARM and ADS-B antennas. The dimensions are approximate for the European FLARM antenna. North American/Australian FLARM antennas and ADS-B are slightly shorter.

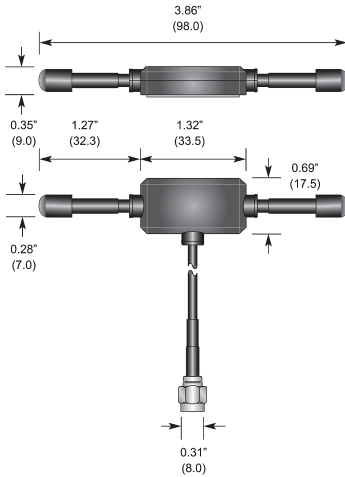

Appendix B: Antennas

For metal and carbon fiber aircraft, it is strongly recommended to install external FLARM antennas (AV-75). These are available from your local FLARM dealer.